

1

2

3

4

5

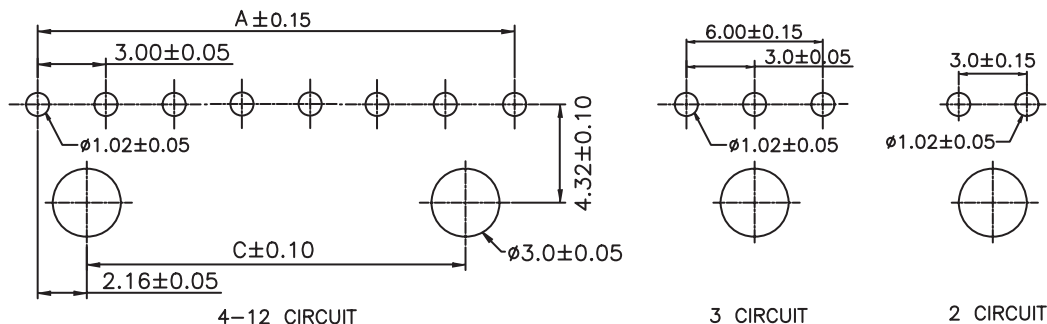

PCB LAYOUT - COMPONENT VIEW

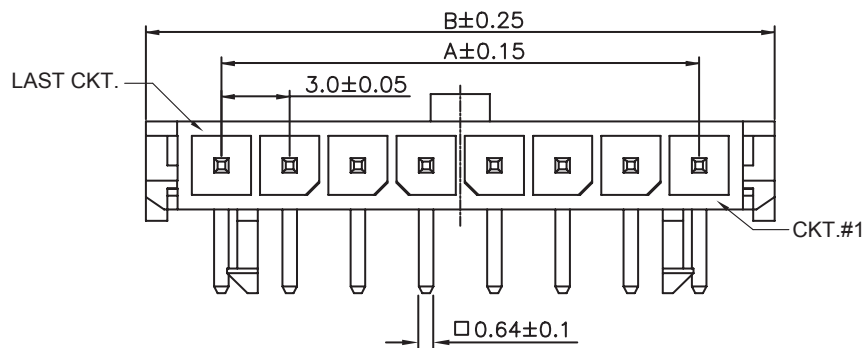
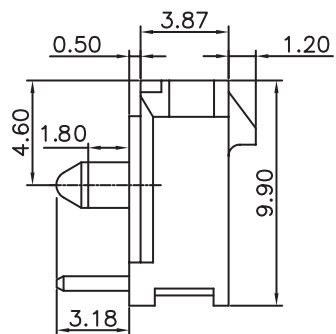

TECHNICAL CHARACTERISTICS

MATERIAL
INSULATOR: LCP
COLOR: BLACK
CONTACT MATERIAL: COPPER ALLOY
CONTACT TYPE: STAMPED
CONTACT PLATING: TIN
QUALITY CLASS: 25 MATING CYCLES
PITCH: 3.00 MM

ENVIRONMENTAL
OPERATING TEMPERATURE: -40 UP TO 105°C
FLAMABILITY RATING: UL94-V0
COMPLIANCE: LEAD FREE AND ROHS

ELECTRICAL
CURRENT RATING: 5 A
WORKING VOLTAGE: 250 VAC
INSULATOR RESISTANCE: >1000 MOHM
DIELECTRIC WITHSTANDING VOLTAGE: 1500 VAC/MN
CONTACT RESISTANCE: 10 MOHM MAX

STANDARD
UL CERTIFIED: E323964

SOLDERING
JEDEC LEAD FREE WAVE SOLDERING PROCESS

PACKAGING
TUBE

DIMENSION
A = 3.00 x (NB. PIN - 1)
B = 3.00 x (NB. PIN + 1) + 0.65
C = 3.00 x (NB. PIN - 3) + 1.70

RoHS Compliant

PROJECTION:

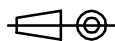

GENERAL TOLERANCE

.X = +/- 0.2

.XX = +/- 0.15



K	05-NOV-15	TPK	AK
J	02-JUL-15	PINNING	AK
I	28-AVR-15	PEG DIMENSION	QP
H	17-FEB-14	SOLDERING	QL
REV	DATE	FILE	BY

APPROVAL: BBu

UNIT: MM

SCALE:

SHEET: 1/3

DRAW: PEARL

DESCRIPTION: 3.00 MM MALE SINGLE ROW RIGHT ANGLE HEADER WITH PLASTIC PEGS

WERI PART NO: 662 0xx 110 22

SIZE

A4

1

2

3

4

5

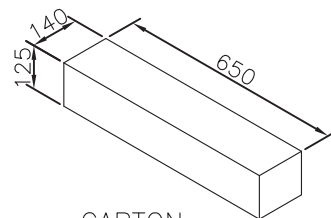
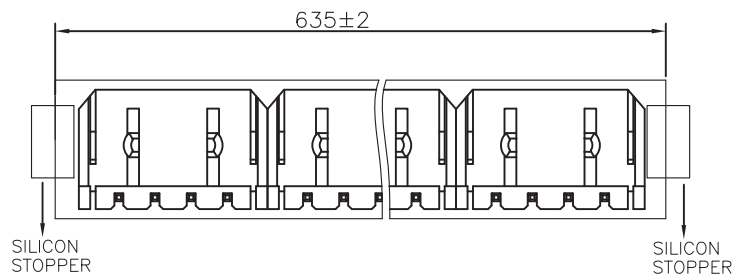
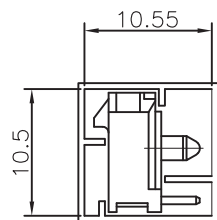

CARTON

Pin	Pcs/Tube	Tube/Carton	Pcs/Carton
2	63	100	6300
3	48	100	4800
4	39	100	3900
5	32	100	3200
6	28	100	2800
7	24	100	2400
8	22	100	2200
9	20	100	2000
10	18	100	1800
11	16	100	1600
12	15	100	1500

RoHS Compliant

PROJECTION:



GENERAL TOLERANCE

.X = ± 0.2 .XX = ± 0.15 

APPROVAL: BBu

UNIT: MM

SCALE:

SHEET: 2/3

DRAW: AK

DESCRIPTION: 3.00 MM MALE SINGLE ROW RIGHT ANGLE HEADER WITH PLASTIC PEGS

WERI PART NO: 662 0xx 110 22

SIZE

A4

REV	DATE	FILE	BY

A

B

C

D

1

2

3

4

5

Cautions and Warnings:

This electronic component is designed and developed with the intention for use in general electronics equipments.

Before incorporating the components into any equipments in the field such as aerospace, aviation, nuclear control, submarine, transportation, (automotive control, train control, ship control), transportation signal, disaster prevention, medical, public information network etc. where higher safety and reliability are especially required or if there is possibility of direct damage or injury to human body, Würth Elektronik must be asked for a written approval.



In addition, even electronic component in general electronic equipments, when used in electrical circuits that require high safety, reliability functions or performance, the sufficient reliability evaluation-check for the safety must be performed before by the user before usage.

A

B

C

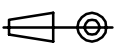
RoHS Compliant

G				PROJECTION: 	GENERAL TOLERANCE .X = +/- 0.2 .XX = +/- 0.15		
F							
E							
D							
C				APPROVAL: JC	UNIT: MM	DESCRIPTION: DISCLAIMER	SIZE A4
B					SCALE:		
A	10-SEP-14	PDF	QL		SHEET: 3/3	WERI PART NO: DISCLAIMER	
REV	DATE	FILE	BY		DRAW: QL		

D